

【Preface】

Thank you for choosing flap /slide barrier and swing gate, This is a product with high technology, so please read this manual carefully before operation.

Please keep this manual for future reference.

Only trained professionals who understand electric and mechanical risk of product are qualified to install and operate gate system so as to avoid unnecessary dangers caused by misoperation.

All rights to improve and perfect our products are reserved. We can't promise this manual is in full accord with the product you receive, but we will check and revise the manual at regular interval. No further notification will be sent in the case of any modifications to the manual.

CONTENTS

1 Product introduction.....	4
1.1 Brief introduction.....	4
1.2 Product structure and principle.....	4
1.3 Function Features.....	7
1.4 Technical parameters.....	7
2 Equipment Installation.....	8
2.1 Installation notes.....	8
2.2 Equipment Installation.....	9
2.3 Connection.....	11
2.4 Debugging instruction.....	13
2.5 Use notes.....	14
3 Board and parameter instruction.....	15
3.1 Board instruction.....	15
3.2 Wiring diagram.....	17
3.3 parameter instruction.....	19
4 Trouble shooting and maintenance.....	21
4.1 Trouble shooting.....	21
4.2 maintenance.....	23

1 Product introduction

1.1 Brief introduction

The flap /slide barrier and swing gate is a kind of 2-way speed access control equipment designed for places with high class security requirements. It is easy to combine IC access control, ID access control, code reader, fingerprint, face recognition and other identification devices, It realizes the intelligent and efficient management of passage.

1.2 Product structure and principle

The structure of the product is mainly composed of mechanical system and electric control system.

The mechanical system is composed of cabinet and core mechanism. The cabinet is equipped with indicator, infrared sensor and other device.

The core mechanism is composed of motor, position sensor, transmission, shaft.

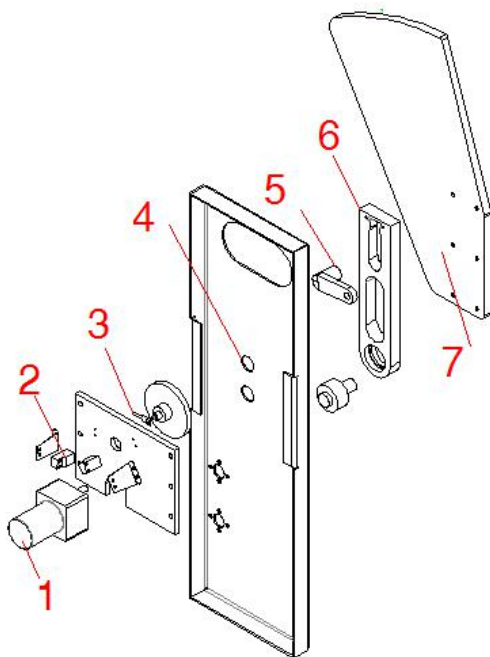

1. Motor
2. Position sensor
3. Induction plate
4. Bearing
5. Transmission shaft.
6. Swing arm
7. Barrier

Flap core

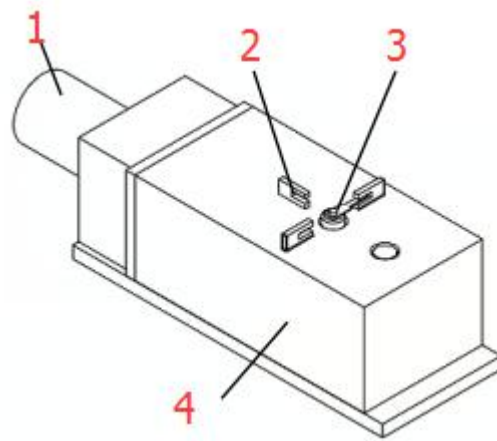

1. Motor
2. Position sensor
3. Induction plate
4. Core

Swing core

The electric control system consists of access control system, control board, infrared sensor, direction indicator, position sensor, motor, power supply, battery and so on.

NO	Name	Function
1	Access control device	IC/ID card access control, fingerprint, face recognition, code reader, access control device send delay signal to the turnstile board door signal (mach)
2	Main board	The control center of the system, when receiving the access control device delay signal, it control motor running so that the gate opened, the direction indicator light turns green, while receiving core position sensor, infrared sensor, and judging and processing logic of these signals, keep the gate components of intelligent coordination work
3	Infrared sensor	Detect the passage of people in the lane, Anti pinch
4	Indicator	Display the current channel status
5	Position sensor	Detects and controls the opening and closing position

		of the gate
6	Motor	Drive the barrier moving
7	Power Supply	power supply to control board
8	12V battery	The gate will keep open the door automatically when power failure

System Operation Principle

- 1) Turn on the power, 3 seconds later; the system enters into work mode;
- 2) After swipe legal card or code and fingerprint, Access control device send opening signal to main board.
- 3) The main board receives open signal, control indicator to green, motor acts to open the barrier.
- 4) After the passenger passing through the passage in accordance with the direction indicator mark, the infrared sensor detects the complete process of the passenger passing through the passage, and issues signal continuously to the main controller board, until the passenger passes through the passage completely.
- 5) After the passenger passes through the passage completely, the main controller board delivers a signal to the counter, which will increase 1 automatically, ending the passing process.
- 6) If the passenger forgets to swipe card when go into the passage, sound/light alarm signal will be given from main board. The alarm signal will not be cancelled until the passenger retreats from the passage and the passing is only allowed after reading again the effective card

1.3 Function Features

- ◆ Varied pass mode can be chosen flexibly;
- ◆ Standard signal input port, can be connected with most of the access control board, fingerprint device and scanner other equipment;
- ◆ The turnstile has automatic reset function, if people swipe the authorized card, but don't pass through within the settled time, it need to swipe card again for entry;
- ◆ Card-reading Recording function: single-directional or bi-directional access can be set by the users
- ◆ Automatic opening after emergency fire signal input
- ◆ Pinch protection;
- ◆ Anti-tailgating control technology
- ◆ Automatic detection, diagnosis and alarm, sound and light alarm, including trespassing alarm, anti-pinch alarm and anti-tailgating alarm.
- ◆ High light LED indicator , displaying passing status.
- ◆ Self diagnostic and alarm function for convenient maintenance and use
- ◆ Gate will automatically open when power failure(connect 12V battery)

1.4 Technical parameter

Housing Material	304 stainless steel
Power	AC220±10% V、 50HZ
Working voltage	DC 24V
Motor	Brush DC motor 30W
Working temperature	-20 °C - 60 °C

Work environment	$\leq 90\%$, no condensation
Open signal	Passive signals (relay signals, dry contact signals,)
Communication	RS485
Pass rate	≤ 35 person/min
Passage width	Flap gate 550mm Swing gate 600--900mm

2 Equipment Installations

2.1 Installation notes

- ❖ Please read this manual carefully before install it;
- ❖ The gates must be correctly arranged in order, and the left and right gates of each lane should be aligned;
- ❖ If the equipment is used outdoors, equipment should be installed at the establishment of 100-200mm high cement platform, so as to prevent moisture, and install ceilings and other sunscreen, rain protection facilities;
- ❖ Protective earth wire must be connected;
- ❖ Please confirm each RJ45 cable straight through;
- ❖ Please check all wires has been properly connected before power on;
- ❖ Please test all function before using.

2.2 Equipment Installation

1) Tool preparations

1	A set of hexagon spanner	5	Screw driver and other common wiring tool
2	Cross screwdriver 6mm	6	Millimeter
3	Open spanner 17-19mm	7	M12x100 Expansion screws 8pcs
4	Impact drill(including D16 and D14 drills)	8	Cable Tester

2) Ensure the installation location and the system composition ,prepare to install after carrying out the system planning;

3) Make well of installation of equipment foundation base.

4)Put the turnstile in order and alignment .We have mark on the turnstile for the multichannel, please install the turnstile in order, such as A1-A2-A3-A4 on one side a1-a2-a3-a4 on the other side.

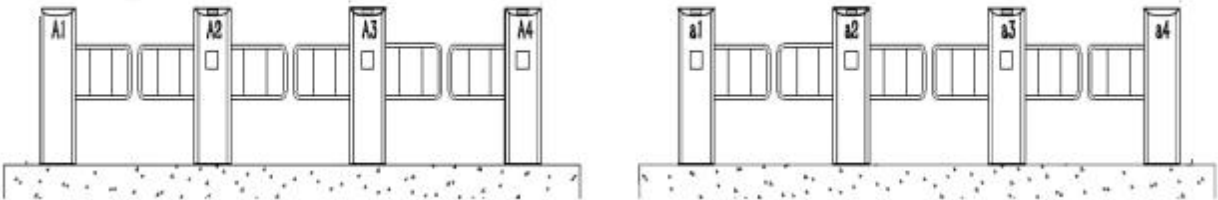
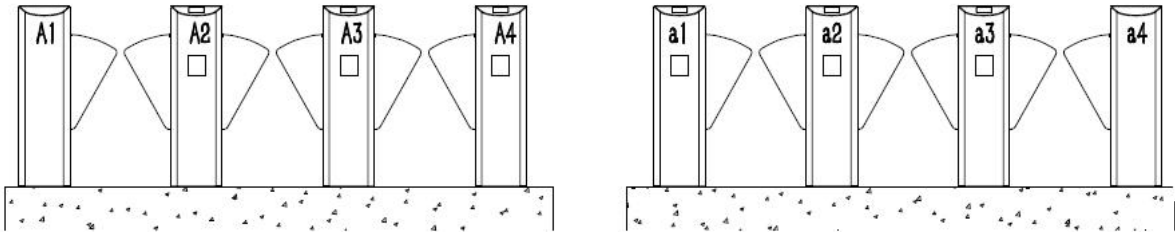

5) Mark the fixing position of expansion bolts according to fixing plate on the bottom of each turnstile.

6) Move turnstile and drill hole by impact drill, fix Expansion screws

7) Tighten the expansion screw after the functional test is completed

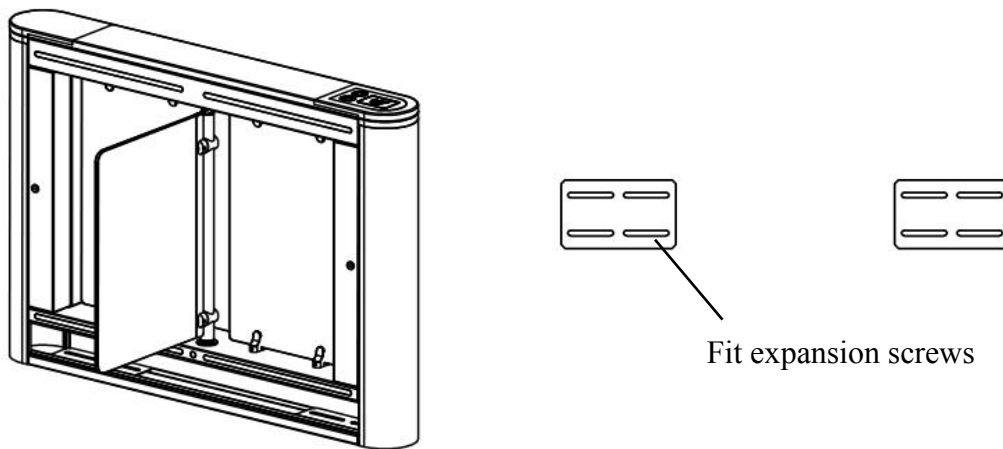
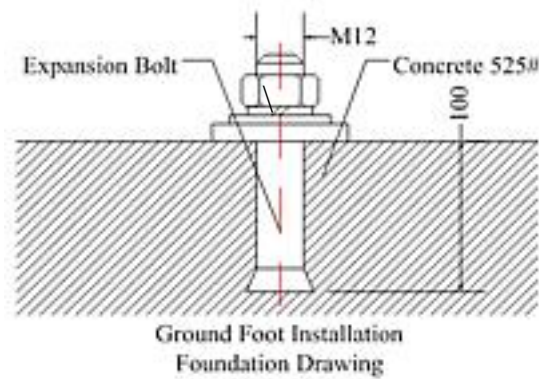

8) Confirm the lane lines, dig line pipe diameter into the appropriate PVC line pipe, each lane will AC220V power line RVV3*1.5mm and 3pcs CAT 5 cable for connect main machine , 1 PCS network cable for access control system (if install other control system according to the actual situation of laying related field the wire)

9) Move each machine to the corresponding mounting position and point to the expansion bolt position;

10) Check again;

11) Check each gate alignment, all lane are completed debugging and function test, then tighten the nut.

12)

2.3 Connection

1) Connect Cable between the master and the vice machine

One lane be control by one control board install in the master machine, so the vice machine must be connected correctly to mater machine by two same sign little connect board. (3 PCS cat5 Cables use for straight-Through). such as 1--1,2--2,3--3(CON1--CON1,CON2--CON2,CON3--CON3)

Refer to the following picture.

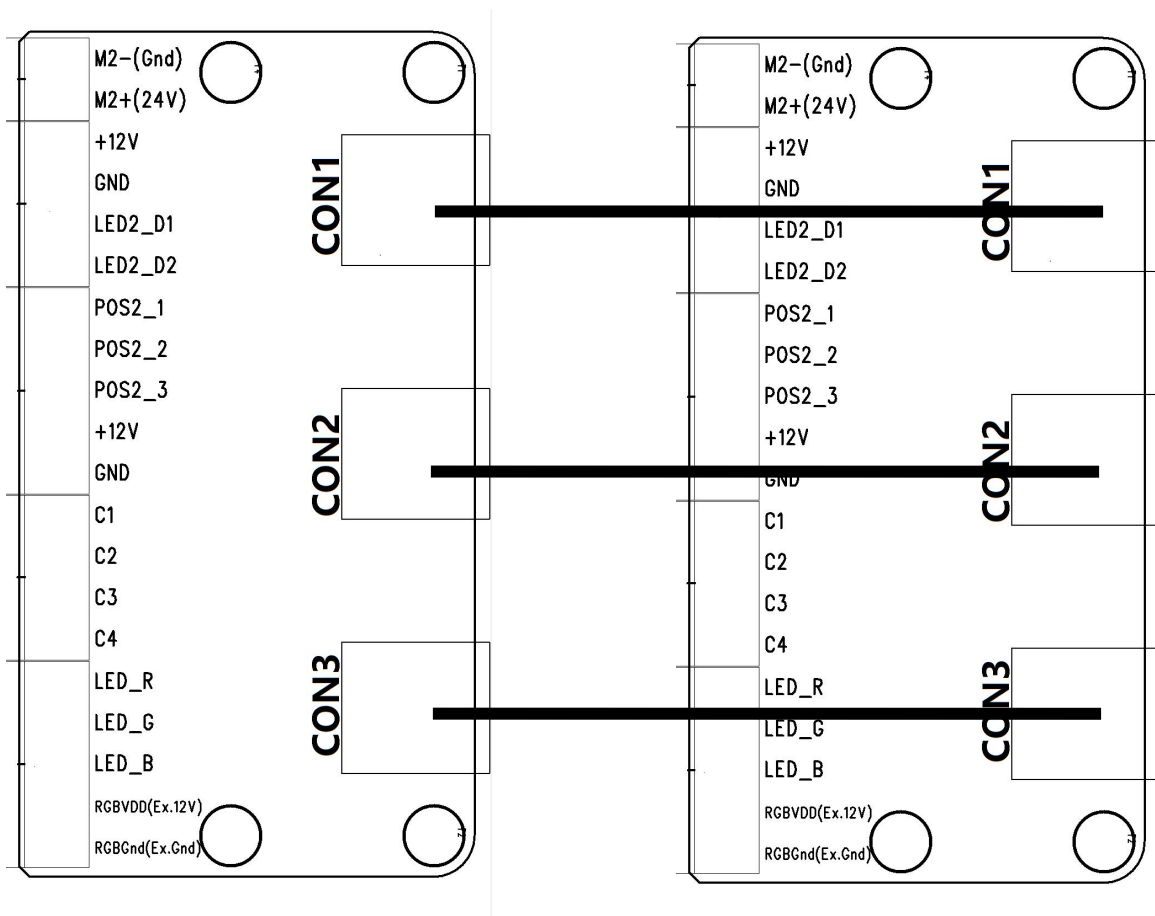

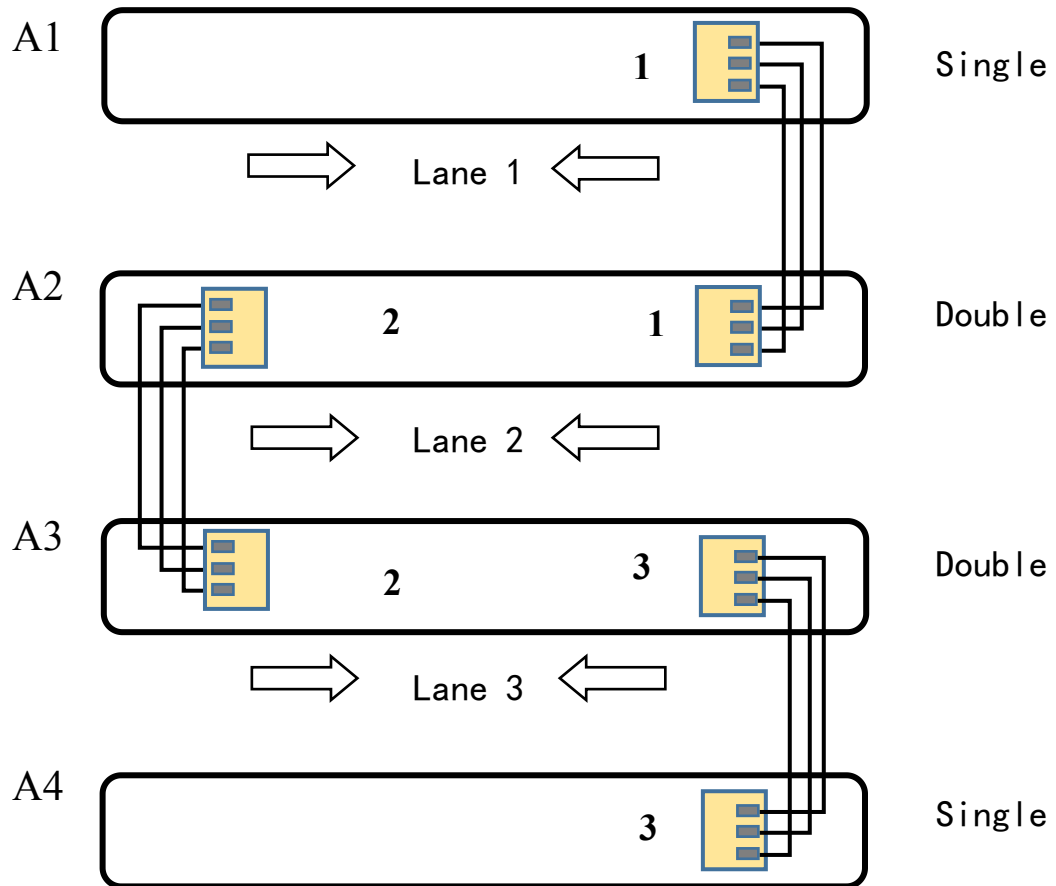

Remarks: each lane is connected by 3 PCS cat5 cables (straight-Through)

2) Connecting AC220V power input

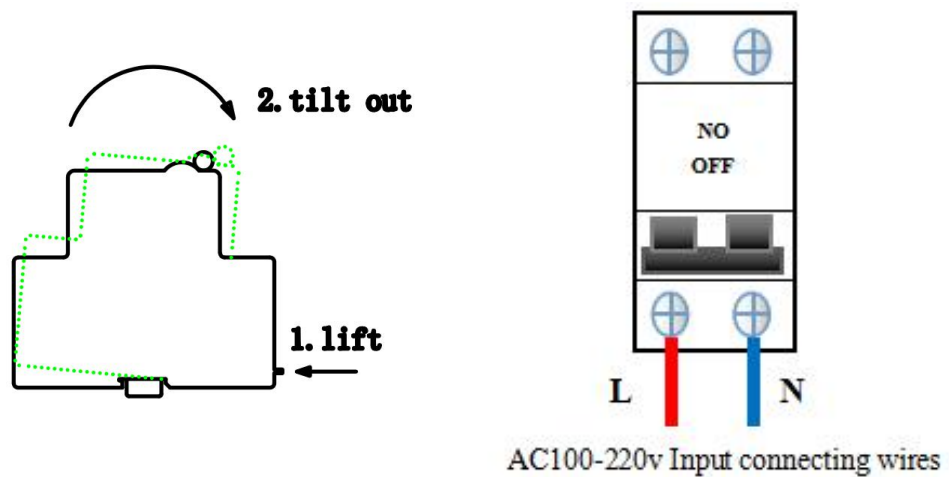

3) Access control device connect

Access control device send open signal to control board , gate will open immediately ,The relay time of access control device must be set to 0-1 seconds.

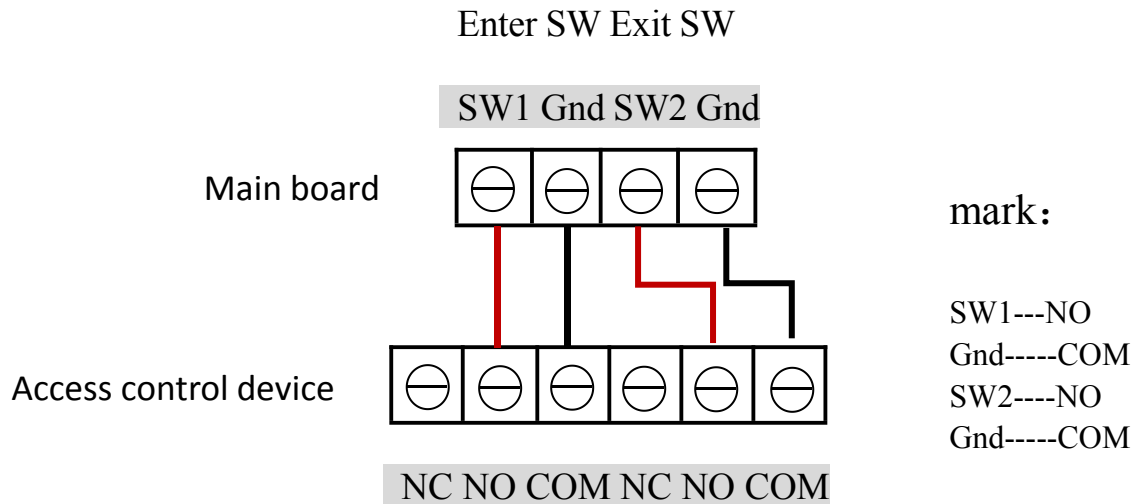

2.4 Debugging instruction

1) Check wire: Check whether the connection wire of the gate and the power line are properly connected before power on. If there is any abnormality on the power supply process, check the connection wires firstly;

2) Function test: After power on the machine will open- close, and open -close, this process is machine self-check, after the sound from buzzer means finish self-check. Don't stand in the lane in the process of self-check;

3) The control board will give alarm if stand in the lane without swipe card ;if no response when infrared sensor be block, please check if the infrared sensors are aligned, Under normal circumstances, the red led of receive sensor is no bright when no blocked .If the red led of receive sensor is always bright ,that means the sensors no shoot well ,please adjust to aligned.

4) The relay time of access control device must be set to 0-1 seconds.

5) When the valid card is swiped, the indicator light turn green, If the indicator indicates incorrect or turn off and alarm immediately when go into first sensor, This means that the signal connection is opposite, exchange the open signal connect terminal of SW1 Gnd to SW2 Gnd

6) Check and test carefully, running smoothly, no abnormal condition, no impact sound, etc; Confirm motor is no idle; the indicator light is correct and the infrared pinch function is normal before putting into use.

2.5 Notice of use

- ❖ If it tests well before installation, then fixed it; before you install and maintain it, please cut off the power;
- ❖ The product must be earthed, and an earth leakage breaker is necessary on the power supply;
- ❖ The depth of buried PVC tube should be greater than 60mm, and the exposed height above the ground should be greater than 50mm. The exit mouth should be bending back to avoid water dipping inside the tube;
- ❖ Don't change the inside wire of the turnstile casually;
- ❖ Please don't open the turnstile when it is under the working status;
- ❖ In installation, please make each door of the lane are in alignment;
- ❖ If you use the turnstile outdoor, it need to add a 100-200mm cement platform for the turnstile to do damp proof, also need to add a canopy to protect the turnstile from sun and rain;
- ❖ Please keep the control button or remote control far away from the children;
- ❖ Please don't use the turnstile under the thunder and lightning condition to get rid of damage to the equipment.

3 Board and parameter instruction

3.1 Board instruction

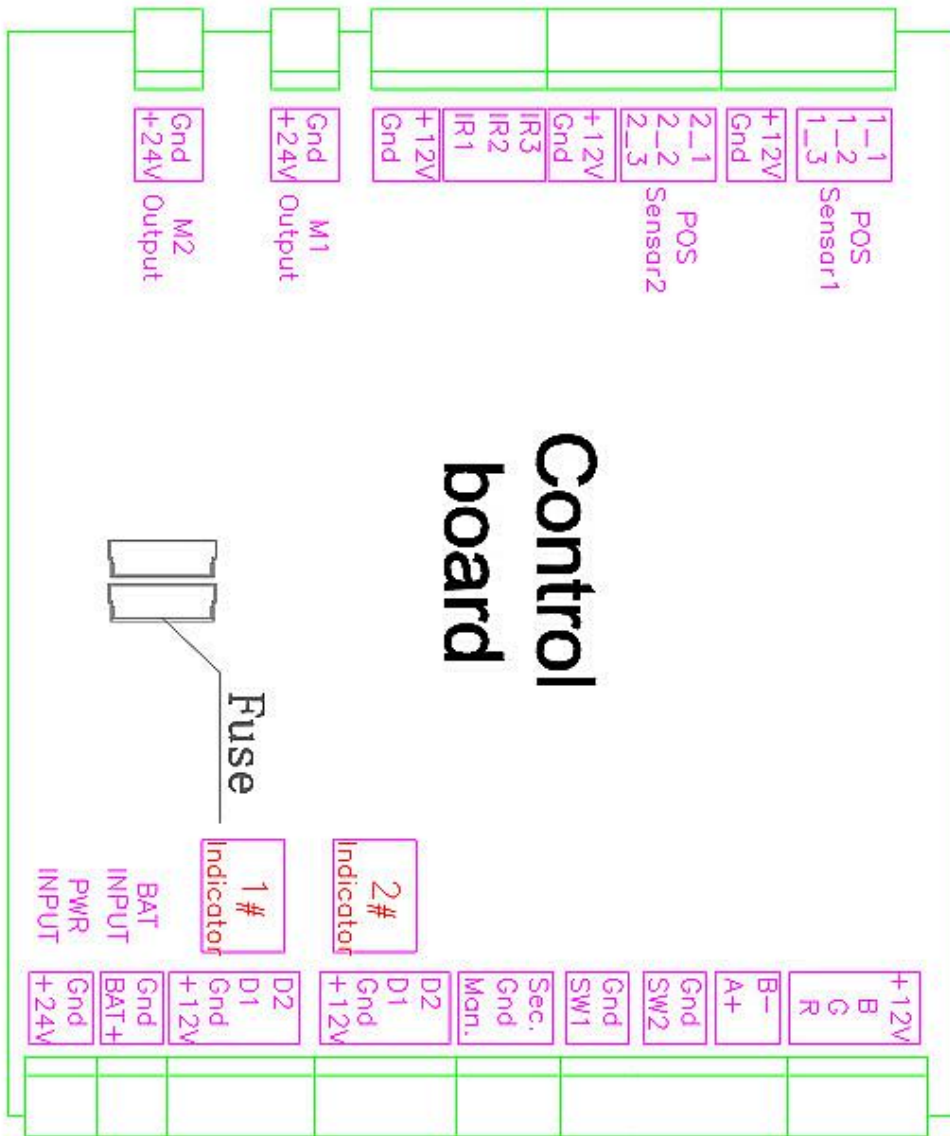

Main board

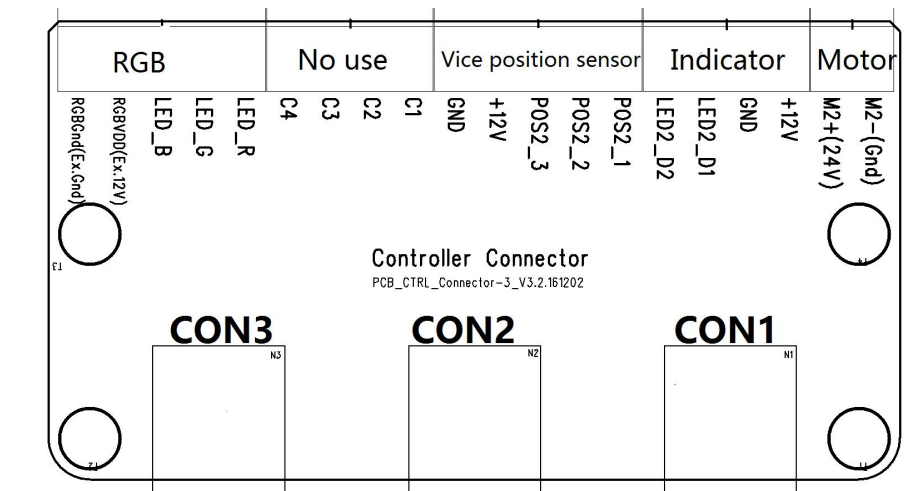

The connect board

Port	Instruction			mark
(1) PWR INPUT	1	+24V	24VDC power supply	Connect to 24V DC power supply
	2	GND		
(2) BAT INPUT	3	BAT+	12V battery input port	Connect the 12V battery, Auto normally open when power off.
	4	GND		
(3) Entry Indicator1	5	+12V	Output for indicator of master machine	Connect to indicator of master machine
	6	GND	D1 for enter direction	
	7	D1	D2 for exit direction	
	8	D2		
(4) Entry Indicator2	9	+12V	Output for indicator of vice machine	Connect to indicator of vice machine
	10	GND	D1 for enter direction	
	11	D1	D2 for exit direction	
	12	D2		
(5) Man Gnd Sec	13	Man	Normally open input Fire alarm input	Short for normally open , Close immediately when cancel
	14	Gnd		
	15	Sec		
(6) Enter SW1	16	SW1	Enter open signal input	Connect to access device NO-SW1 COM-Gnd
	17	Gnd		
(7) EXit SW2	18	SW2	Exit open signal input	Connect to access device NO-SW1 COM-Gnd
	19	Gnd		
(8) COM1 (485)	20	A+	RS485 communication	
	21	B-		
(9) RGB LED	22	R	Negative of LED red	Connect to LED bar
	23	G	Negative of LED green	
	24	B	Negative of LED blue	
	25	+12V	+12V for LED bar	
(10) POS Sensor1	26	1-1	left sensor	Connect to position sensor of core in the master machine, flap /slide gate only use two sensor(open and close)
	27	1-2	Close sensor	
	28	1-3	Right sensor	
	29	+12V	12V output for sensor	
	30	GND		
(11) POS Sensor2	31	2-1	left sensor	Connect to position sensor of core in the vice machine, flap /slide gate only use two sensor(open and close)
	32	2-2	Close sensor	
	33	2-3	Right sensor	
	34	+12V	12V output for sensor	
	35	GND		
(12) IR Sensor	36	IR1	Enter infrared sensor	Control board alarm when sensor be block
	37	IR2	Pinch infrared sensor	
	38	IR3	Exit infrared sensor	
	39	+12V	12V output for infrared	
	40	GND		
(13) M1 output	41	GND	Motor output for mater machie	Connect to motor of master machine
	42	+24V		
(14) M2 output	43	GND	Motor output for vice machie	Connect to motor of vice machine
	44	+24V		

3.2 Wiring diagram

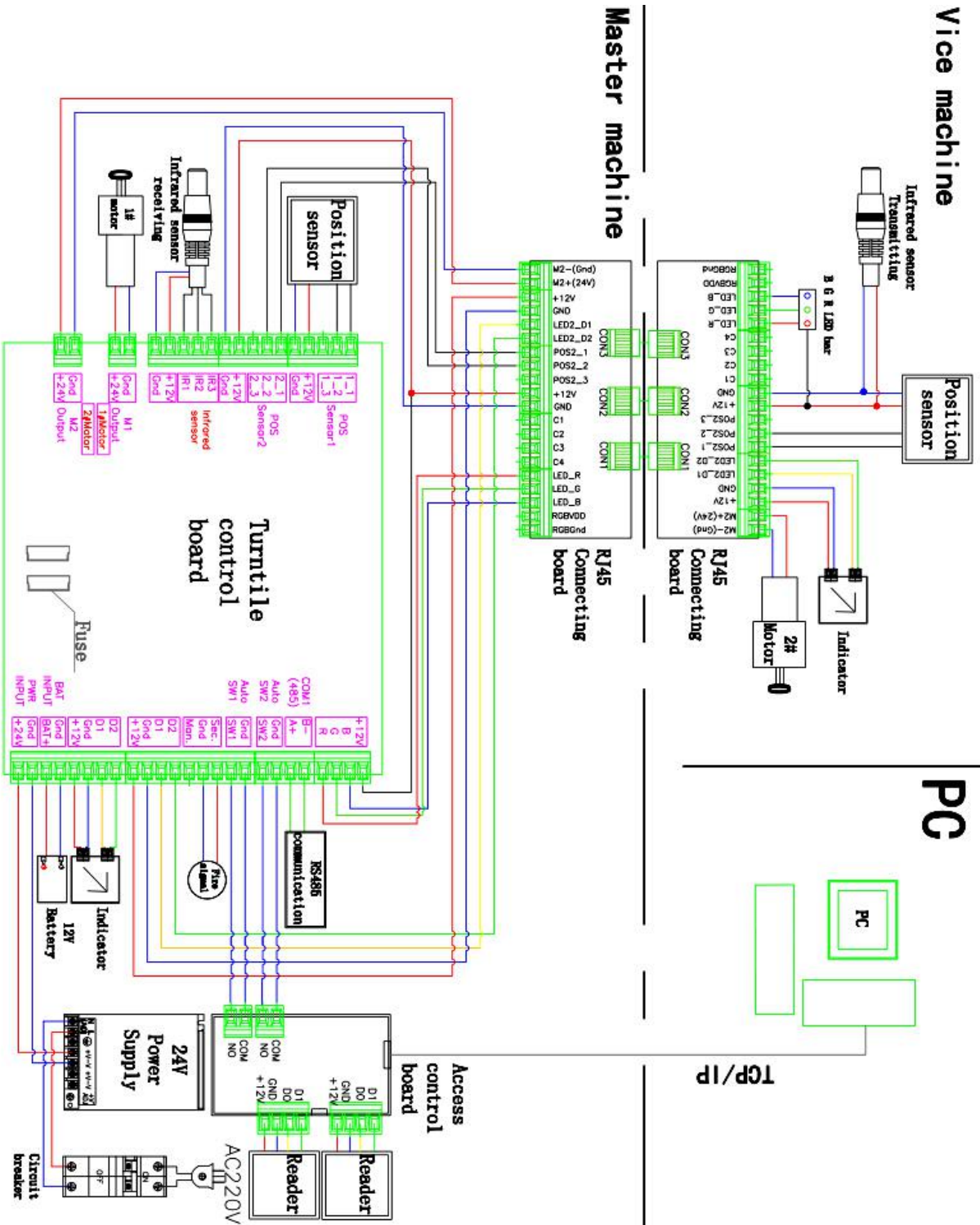

Flap/Slide gate wiring diagram

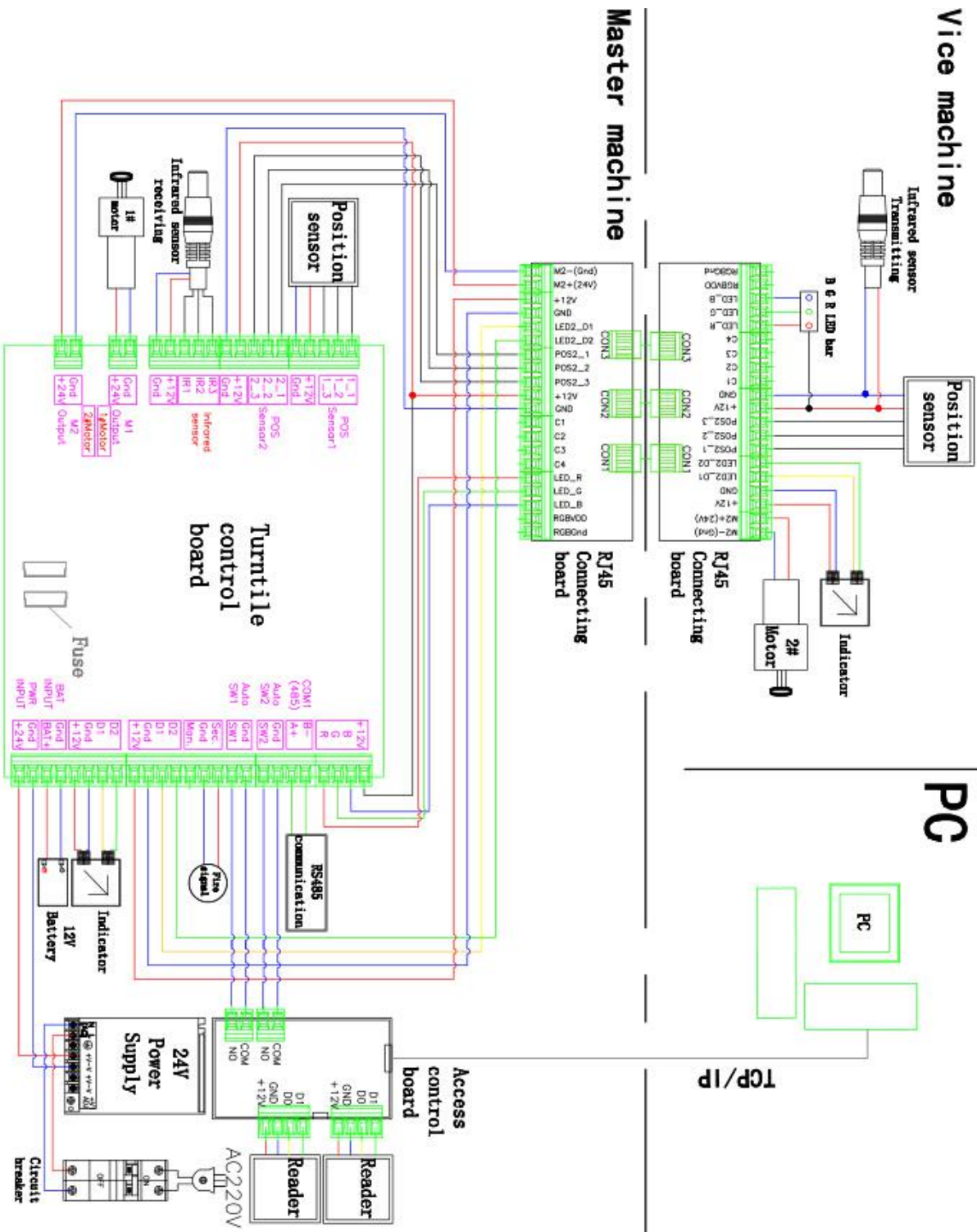

Swing gate wiring diagram

3.3 Parameter instruction

Description: the factory has been set up parameters, please do not modify, if you need to modify the parameters, please proceed under technical guidance.

一、1. Description

1) The display screen is refers to the main control board of 3 LED display from left to right. Four buttons: up and down for switch, ENT for sub-menu, ESC for previous menu.long press right 3 seconds unlock into the menu.



2.Menu setting

Item	Explain
1. Parameters	
1.1 Counter	Display pass through count
1.2 Gate Mode	Set Gate Mode(NO, NC and card, free or reject) of enter and exit 1.NC both Rej 2 .NC both free 3.NC both card (default) 4 NC Card Free 5 .NC Card Rej 6. NC Free card 7.NC Free Rej 8.NC Rej Free 9.NC Rej Card 10.NO Both Free 11.NO Both Card 12.NO Card Free 13.NO Free Card
1.3 PassTimeout	Set maximum waiting time 10-255, unit 0.1s, (default 5seconds)
1.4 Memory	Set Scan Card With Memory Mode 0 two-way disable(default),1. enter allow,2. exit allow,3. two-way allow
1.5 ReadIn Lane	Set Can Scan Card After Entry Lane,Please do not modify 1. disable (default), 2. allow
1.6 Open Delay	Set Authorized Open Door Delay 0-255, unit 0.1s, (default 0)
1.7 CLS. Delay	Set Close Door Delay After Passage Finish0-255, unit0.1s, (default 0)
1.8 Motor1 SPD.	Set master Motor basic speed 1-100
1.9 Motor2 SPD.	Set vice motor basic speed 1-100
1.10 Pass End	Set IR Check passage end position 1. exit (default), 1 safety
1.11 Intrude Set	Set Intrude Alarm Mode 1.no alarm, 2 .alarm (default), 3. alarm and close
1.12 Reverse Set.	Set Passage From Reverse Alarm Mode 1 no alarm, 2. alarm, 3 alarm and close (default),

1.13 Tail-Gating	Set Tail-Gating Alarm Mode 1 no alarm, 2. alarm, 3 alarm and close (default),
1.14 Adv. Param.	
.1 EN_O_SPD.1	Set Motor 1 Speed when Open Door for Entry
.2 EN_C_SPD.1	Set Motor 2 Speed when Open Door for Entry
.3 EX_O_SPD.1	Set Motor 1 Speed when Close Door for Entry
.4 EX_C_SPD.1	Set Motor 2 Speed when Close Door for Entry
.5 EN_O_SPD.2	Set Motor 1 Speed when Open Door for Exit
.6 EN_C_SPD.2	Set Motor 2 Speed when Open Door for Exit
.7 EX_O_SPD.2	Set Motor 1 Speed when Close Door for Exit
.8 EX_C_SPD.2	Set Motor 2 Speed when Close Door for Exit
.9 Save Fact.	Save the current parameter to factory default
.10 Relay Mode	Set add relay use for passed counter 1. disable,(default),2.Enter allow, 3.Exit allow ,4. both allow
.11 Auto Report	Set automatic report gate status when on change 1 disable (default), 2 allow
.12 NO Direction	Set the normally open the gate opening direction , the default enter
.13 Power Lost	Set the normally open the gate opening direction when Power failure , the default enter
.14 Barriers	signal or double machine work 1 double (default) , 2 signal
.15 IR Speed	Set IR Sensor Sensitivity(1-100) 0-100(default 100)
.15 IR Type	Set infrared sensor type 1 PNP (default), 2 NPN
.16 IR Logic	Set Use Local IR Sensor Logic
.17 Motor Pro.	Set the motor over current protection threshold, the default 2.5A
.18 Self Check	Set use self check when power on, disabled by default
.19 LED Mode	Set LED indicator default parameter 1 Static LED,2 Square LED
.20 Set DevType	Set Controller Device Type 1 Tripod 2 Flap gate, 3 Swing gate
2. System Set	
2.1 Language	Set Menu Display Language
2.2 Device Type	Display Controller Device Type
2.3 Version	Display hardware and firmware version information
2.4 Set Address	Set Device Logic Address
2.5 RS485 Baud	Set the baud rate of the RS485
2.6 Reset	Reset all setting to factory default.
2.7 Restart	Restart controller
3. Factory Test	
3.1 Cycle Test	Open and close door cycle test
3.2 Input Check	Check input interface status
3.3 Output Test	Output interface test

4 Trouble shooting and maintenance

4.1 Trouble shooting

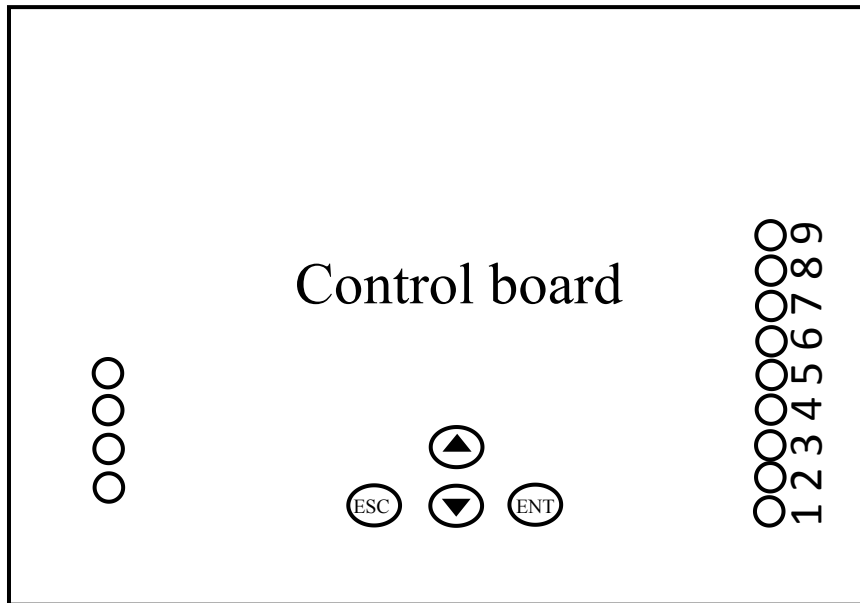

The box of control is buckle type ,It can open the upper cover of the buckle from the side.

Fault 1: Gate automatically open when people in to first sensor?

Answer: Change pass mode two way free to two way card in the menu.

Fault 2: swipe into the first sensor, Gate give alarm and close immediately?

Answer: This means that the signal connection is opposite, exchange the open signal connect terminal of SW1 Gnd to SW2 Gnd.

Fault 3: indicator light is not bright?

Answer: Take the other indicator or control board from other lane and check it

Fault 4: is there an indicator that shows the wrong direction?

Answer: Exchange the connect wire of indicator D1 to D2.

Fault 5: One side of the wing door does not work?

Answer: 1)Check whether the connection wires is loose;2)Turn off the power and use the millimeter to check whether the connection between the master

machine and the vice machine is continuous ;3) Measure whether M1 or M2 has voltage output when restarting the power supply;4) Check fuse in the board.

Fault 6: open and close obvious non synchronization?

Answer: 1) Check whether the POS Sensor connect wires are loose;2) Turn off the power and use the millimeter to check whether the connection between the master machine and the vice machine is continuous.

Fault 7: Motor idling?

Answer: 1) Check whether the POS Sensor connect wires are loose;2) Turn off the power and use the millimeter to check whether the connection between the master machine and the vice machine is continuous.3) Check the vice board 12VGND for voltage output

Fault 8: there is one side of barrier is not closed?

Answer: 1)Check whether the POS Sensor connect wires are loose;2)Turn off the power and use the millimeter to check whether the connection between the master machine and the vice machine is continuous.3) Check the vice board 12VGND for voltage output

Fault 9: swing the side of the pendulum rod can only open 90 degrees, or open the side of the pendulum rod hit the box?

Answer: 1) check the abnormal barrier and the normal one whether there is any difference between the fixed angles and whether the pendulum rod is struck or not 2) Check the iron sheet of core whether is loose, if loose readjust it.

Fault 10: The swing gate move slowly or shake or give big noisy?

Answer: Check core

4.2 Maintenance

Swing barrier gates require regular maintenance by professionals and daily cleaning to ensure long-term stability and extended equipment life.

1. Maintenance Content:

- * Keep the turnstile housing and card reader panels of turnstile gates clean;
- * Fasten and lubricate the internal movement structure;
- * Check the dust of the driver board and make it clean.
- * Check the connectors and wiring points to ensure the reliability of the connection.

2 Maintenance Methods:

1. Cleaning: Check the housing and card reader panels of the gate, and remove the dust and other dirt to make them clean;
2. Rust removal and Lubrication: Check the movement of the flap /slide gate and swing gate, remove rust with sand paper and spread with anti-rust oil if corroded;
3. Screws fastening: Check the connection of the various moving parts, fasten the screws where they are loose to avoid causing fault for long-running;
4. Circuit board cleaning: Cut off the power, and wipe dust of the board by using a clean brush;
5. Lines Checking: Check the connecting lines and solder reinforcement if they are loose off.

Note: This product is the strong professional technical equipment. In addition to daily maintenance, please do not feel free to disassemble it. If a fault occurs while running, Please notify our service departments or the authorized service agencies promptly to have it maintained. Do not disassemble it at random to avoid

damaging the internal structure or even damaging your interests because of your improper operation.

Guarantee Instruction

Our company products are guaranteed for one year, from date of sale, providing free maintenance based on not being damaged by any man-made.

- During the warranty period, all faults caused by the product itself can be maintained for free. Please carry the filled warranty card and the purchase invoice to the authorized service centers across the country or return the machine to our company for free repair.

- Within the period of free maintenance, faults or damages caused by man-made or natural disasters can be maintained with additional charge.

- Over the period of free maintenance, faults or damages can be maintained with additional charge.

The following conditions are not under warranty:

- Damages caused by abnormal operation, man-made or natural disasters;

- Damages after disassembling any portion of the machine (lines, components etc.) ;

- Damages caused by wrong guide of non-professional technicians;

- Damages caused by adding other functions with unauthorized modification or installation with other equipment.

Note: The warranty card and purchase invoice are used as warranty certificates to maintain the machine. Please reserve them carefully. Lose won't repair.

User Data Card

User Name		User Contact		Postcode	
User Address					
Machine Model					
Seller Unit		Seller Contact		Postcode	
Seller Address					
Sell Date					

Maintenance Records

Maintenance Date	Fault Description	Maintenance Method	Maintenance Man	Maintenance Unit Seal